



Q7

Audi Q7





Page				
Fascination				
	4	Audi Q7		
Technology				
	27	Audi innovations	35 quattro	
	29	Simplexity	37 Performance	
	31	Lighting technologies	39 Audi ultra	
Equipment				
	43	Engines	55 Lights	61 Assistance systems
	47	Paint finishes	56 Design	63 Technology/safety
	49	Wheels/tyres	57 Steering wheels/controls	
	51	Seats	58 Comfort	
	53	Inlays	59 Infotainment	
Other				
	65	Dimensions	66 Technical data	
Audi Genuine Accessories				
	68	Audi Genuine Accessories	78 Communication	
	70	Sport and Design	81 Family	
	74	Transport	88 Comfort and protection	
			96 Technical Data	



**Greatness
starts, when
you don't stop.**



The epitome of quattro – given progressive form.
Powerful and striking.



Everything an Audi Q7 should be:
athletic, timeless, unique.



**Self-confidence has found its shape.
Now you're ready for anything.**



Pushing to the limit always keeps you ahead.

Dynamism that makes its mark. Created by the powerful and efficient 3.0 L TDI engine. Generously designed for engine power and power delivery. Fuel consumption and emissions kept in check. High-level performance that adapts itself to your personal driving style. Thanks to the 8-speed tiptronic and Audi drive select. From comfort in 'comfort' mode to very sporty in 'dynamic' mode. With improved cornering on fast roads. So that you can extend your lead on any road.





quattro. Driving confidence in every situation.

35 years of quattro. A never-ending success story. And one whose next thrilling chapter is set to impress. In the new Audi Q7. With the tried-and-tested quattro drive. Increased traction comes as standard. For excellent driving dynamics. Permanently. Underpinned by the new Audi drive select modes, such as 'Allroad'. Making impressive use of all this car has to offer.



Seeing further will also get you further ahead.

Shedding light on the future. With optional Audi Matrix LED headlights. Their crystalline shine ensures bright, homogeneous illumination of the road. Clarity right down the line. Thanks to high-precision, individually controlled light-emitting diodes. Making a visible impression. LED rear lights are also standard. Plus optional dynamic indicators at the rear. Safety and comfort shine in a new light.



Comfort on a higher level.

The interior concept of the new Audi Q7: space to unleash your ideas. High quality Cricket leather adorn the comfortable seats and the spacious cabin.



Premium quality, excellent workmanship. Seen and felt in the high-quality Cricket leather upholstery. Elegant atmosphere included. Double inlays. Just as you like it. You can also tailor the automatic air conditioning to your wishes. And, if you want, those of your passengers with the 4-zone air conditioning systems.



You only thought you'd seen everything.

The future of mobility is right here. It's plain to see from the driver's seat. With the optional Audi virtual cockpit. The fully digital instrument cluster with high-resolution 31.242cm display. A host of information the driver needs clearly in sight. Razor-sharp, brilliant and rich in contrast. With MMI navigation plus with MMI touch on request. Additional 21.082cm display area with the extending MMI display. Intuitive operation included. Thanks to the intelligent new MMI control concept. Fewer buttons, more functions. Vehicle settings, navigation, telephone, and media. An even larger touchpad for even easier operation. Using the complex technology then becomes child's play. So you can relax and focus on discovering new destinations.



Flexibility creates new space.

Space redefined. Or simply taken literally. Made possible by a seat and loading concept that concentrates solely on what's essential. You. With a generous feeling of space. And many different configuration options. For the right number of seats and amount of luggage at any given time. With a comfortable bench seat as a second row and a third row of seats.

With two individual seats and electrically folded and raised backrests.

Easy entry comes as standard.



Leaving virtually no trace allows you to make your mark.

The new Audi Q7 makes its mark in many ways. Trend-setting design. Thrilling performance. Innovative technologies. And needs an exclamation mark when it comes to lightweight construction. Up to 325 kg weight reduction compared to its predecessor. Achieved through progressive ideas and an intelligent mix of materials. For even better driving dynamics.





quattro

Vorsprung is superb.

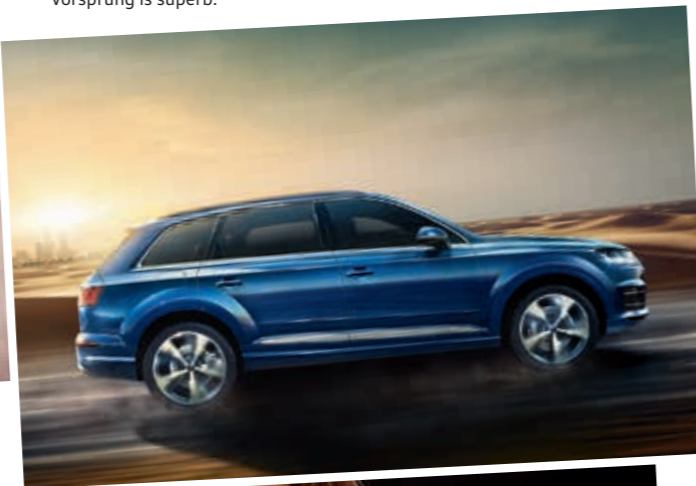

Audi MMI

Vorsprung connects.



Vorsprung

durch Technik.

Simplicity

Vorsprung simplifies.



Performance

Vorsprung accelerates.



Audi ultra

Vorsprung is sustainable.



Lighting technologies

Vorsprung is pioneering.



Assistance systems

Vorsprung means safety.

Audi takes you further.

The world is constantly changing. Technology is advancing at an ever faster pace. And in the process, more and more opportunities are opening up to you – nowhere more so than in the field of mobility. We are playing an instrumental role in shaping this progress. With a constant stream of new innovations. Striving to provide you with vehicles that enrich your life – and to help you get ahead in your mobile life.



Simplexity | Vorsprung simplifies.

Never lose sight of the big picture.

→ **Voice control system**
allows you to use everyday language to control many essential functions of the car phone, radio, CD player and the navigation system.

→ **Multifunction leather steering wheel**
including shift paddles. Allows you to control many functions, including the driver information system, without moving your hands from the steering wheel.

→ **Audi MMI**
increases driving comfort with an intuitive control and display system for infotainment and vehicle functions, including inter-device MMI search by entering free text.

→ **Audi virtual cockpit**
Control a host of functions and MMI services displayed within your field of vision. You also have the choice between the 2 display variants classical and progressive, which show a wealth of information the driver needs in brilliant image resolution.

Streamlined. Clearly arranged. Logical. The world of mobile infotainment: with the Audi Multi Media Interface (MMI) and many other controls that allow you to easily negotiate in the cockpit without losing sight of what's happening on the road. Together, they make phoning and navigating highly intuitive, highly functional and highly convenient – not least thanks to a wide range of equipment, such as the voice control system, Audi virtual cockpit or Audi phone box. Experience how easy and intuitive equipment can be to operate.

→ **Audi phone box**
allows phone calls to be made in the vehicle with improved reception quality.



Lighting technologies | Vorsprung is pioneering.

See and be seen better.

Darkness is relative. The optional Audi Matrix LED headlights virtually turn night into day. State-of-the-art, pioneering lighting technology for excellent and intelligent illumination of the road. For increased visibility. And to attract attention. But Audi Matrix LED headlights won't thrill you only at night. They're a spectacle during the day too.



→ **Audi Matrix LED headlights**

are controlled by a camera and software to suit the course of the road and the position of other road users, illuminating the given scene using innovatively configured, dimmable LEDs in near-daylight colour. For even more safety on the road.

Assistance systems | Vorsprung means safety.

Relax even before you get there.

Each drive is different. Yet they all have one thing in common – the feeling of being protected that you get from every Audi. Many driver assistance systems in your new Audi Q7 help you during your journey and guarantee even greater comfort while you're on the road. Get to know the most important driver assistance systems.

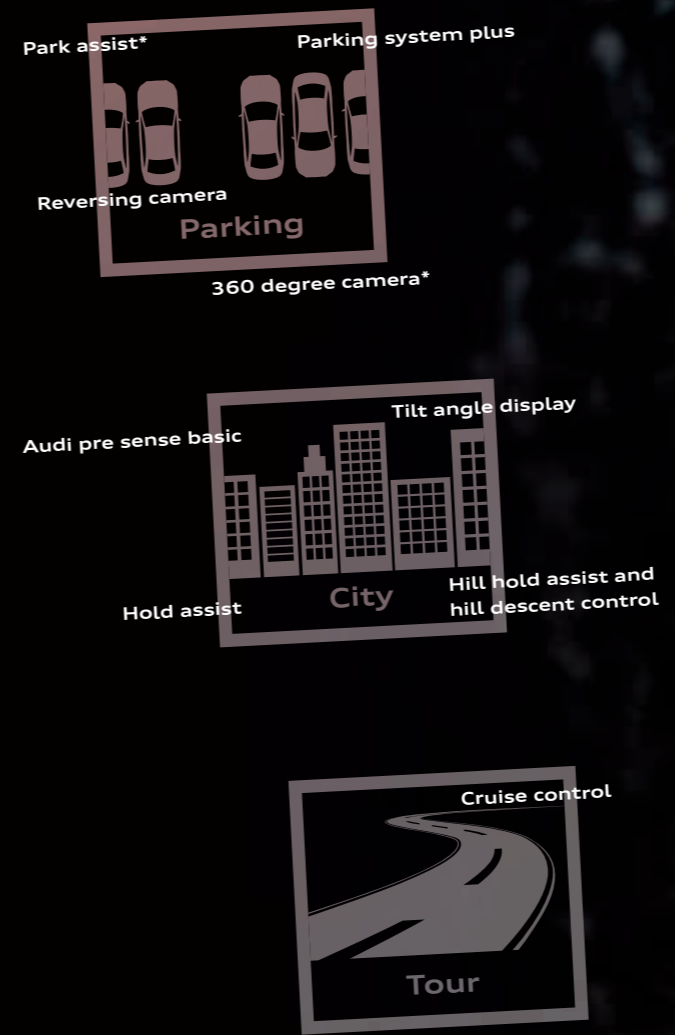

*Optional



quattro

quattro | Vorsprung is superb.

All conditions are perfect conditions.

Have the road completely under control, thanks to permanent distribution of the drive force to all four wheels. The rear axle is variably controlled via a self-locking centre differential. Always as the situation demands, always selective. Experience handling stability, dynamism and agility as never before and combat the effects of over and understeer with quattro. For increased traction and superior propulsive power. Tame any road. And always keep your eyes set on where you're heading. On bends. On straights. On nearly any surface. For a fascinating experience that sticks. To the road and in your mind.

→ **Wheel-selective torque control**
improves driving stability during fast cornering.

→ **Centre differential**
distributes the drive force between the axles as needed.

Performance | Vorsprung accelerates.

Get the most out of every drive.

Get in. Buckle up. Start the engine. Wherever you're heading, enthralling driving dynamics will power you there. For as you know, the world is your oyster once you get behind the wheel of your Audi Q7. You decide the direction. The driving style. The pace. With higher power and lower fuel consumption. And enjoy the satisfaction of knowing you have plenty in reserve. More than enough to get the very best from every drive.

TDI

With their combination of direct injection and turbocharging, Audi TDI engines promise exceptional performance thanks to their high torque output over the entire engine speed range with constant power build-up. They are renowned for being fuel-efficient and for reducing emissions. But they are incredibly dynamic too, letting you get the maximum out of any road.

TFSI

A radical shift from convention, Audi TFSI combines direct injection with forced induction supercharging or turbocharging. This unleashes higher power output with greater fuel efficiency and produces outstanding responsiveness—making the engine more of an extension of the driver.

adaptive air suspension

The electronically controlled air suspension including tilt angle display acts separately on each of the 4 wheels, providing for balanced handling characteristics even with a heavy load. Also available as a sport version with even stiffer damping.

Audi drive select

The standard Audi drive select lets you adjust the driving characteristics of the new Audi Q7 to suit your requirements. At the push of a button. Sportier, more comfortable, more balanced, more economical or even tailored to your requirements – you decide.



ultra

Building an Audi is an extremely complicated business. And yet a simple principle applies for all models: all vehicle components interlock precisely in order to produce emission-reducing synergies. What started in accordance with this principle at the end of the 1980s with Audi lightweight construction and the revolutionary Audi Space Frame (ASF) is now known as the reversal of the weight spiral: every lightweight component has an impact on other components, which can in turn be made smaller. In this way, existing forms and materials are continuously being improved with regard to their functionality,

the lowest possible weight and their production process. With the goal of building vehicles that are even more efficient and make more sparing use of resources. At the same time, more and more efficiency technologies are being built into an Audi. These include recuperation and the start-stop system. Not to mention progressive, efficient high-tech engines. For greater driving dynamics, high compression, more efficient combustion and lower CO₂ emissions. All this is known as Audi ultra. Today and in the future – towards CO₂-reduced mobility.

→ Lightweight expertise

Less weight. More savings, power and endurance. Audi lightweight technology. What started with lightweight body construction has now made its way into nearly all areas, combining innovative materials such as aluminium, carbon and magnesium, intelligent design principles and resource-saving manufacturing processes into an overall concept.

→ Aerodynamics

Less drag, more efficiency. Thanks to the consistently aerodynamic styling of the vehicle's lines, its underbody and spoiler edges – in order to achieve the best possible form for aerodynamic efficiency. Not forgetting tyres with reduced rolling resistance. All tested in the Audi wind tunnel at up to 300 km/h.

→ Engine expertise

Powerfully and efficiently driven. By Audi ultra with efficiency technologies in the engine sector. For example, with the efficient thermal management, which lowers the energy consumption of the engine can be used to reduce emissions.

Audi ultra | Vorsprung is sustainable.

The sum of our
most efficient ideas.

→ Recuperation

Braking that leads to even more efficient driving. With brake energy recovery (recuperation). Part of the kinetic energy produced when braking and coasting is temporarily stored in the vehicle's battery and then used when accelerating. Depending on the driving cycle, this can save up to 3 % of fuel.

→ Transmission expertise

Improved efficiency thanks to improved transmission ratios. A higher torque output makes longer ratios possible, especially in higher gears. For powerful torque in the low engine speed range which reduces fuel consumption, yet has no adverse effects on driving performance and sportiness.





As unique as you are.
The equipment options.

Sportiness, comfort, design, functionality – whatever you demand of your Audi, it offers you a wealth of equipment.

The right driving force for every personality.

No matter which Audi engine you choose, they all have high compression ratios, highly efficient combustion and outstanding efficiency. In short, they deliver more power whilst using less fuel and producing fewer emissions.



3.0 TDI quattro

TDI

Audi TDI engines: high torque output over the entire engine speed range – with constant power build-up. They are renowned for being fuel efficient and for reducing emissions. The 3.0 TDI quattro, has a power output of 183 kW, a top speed of 234 km/h and accelerates from 0 to 100 km/h in 7.1 seconds.



2.0 TFSI quattro

TFSI

Audi TFSI engines: higher power output with greater fuel efficiency and produces outstanding responsiveness. The 2.0 TFSI quattro has a power output of 185 kW, a top speed of 250 km/h and accelerates from 0-100 km/h in 7.1 seconds.

Your Audi is painted not just once. But four times.

When you choose a paint colour, choose one that best reflects your own personality. But whichever colour you opt for, you can count on the outstanding quality of our painting process. Though no thicker than a human hair, the layer of paint on an Audi is actually made up of four different coats. So not only do you look radiant in your Audi, the car is also protected from environmental influences and wear. For its entire lifetime.

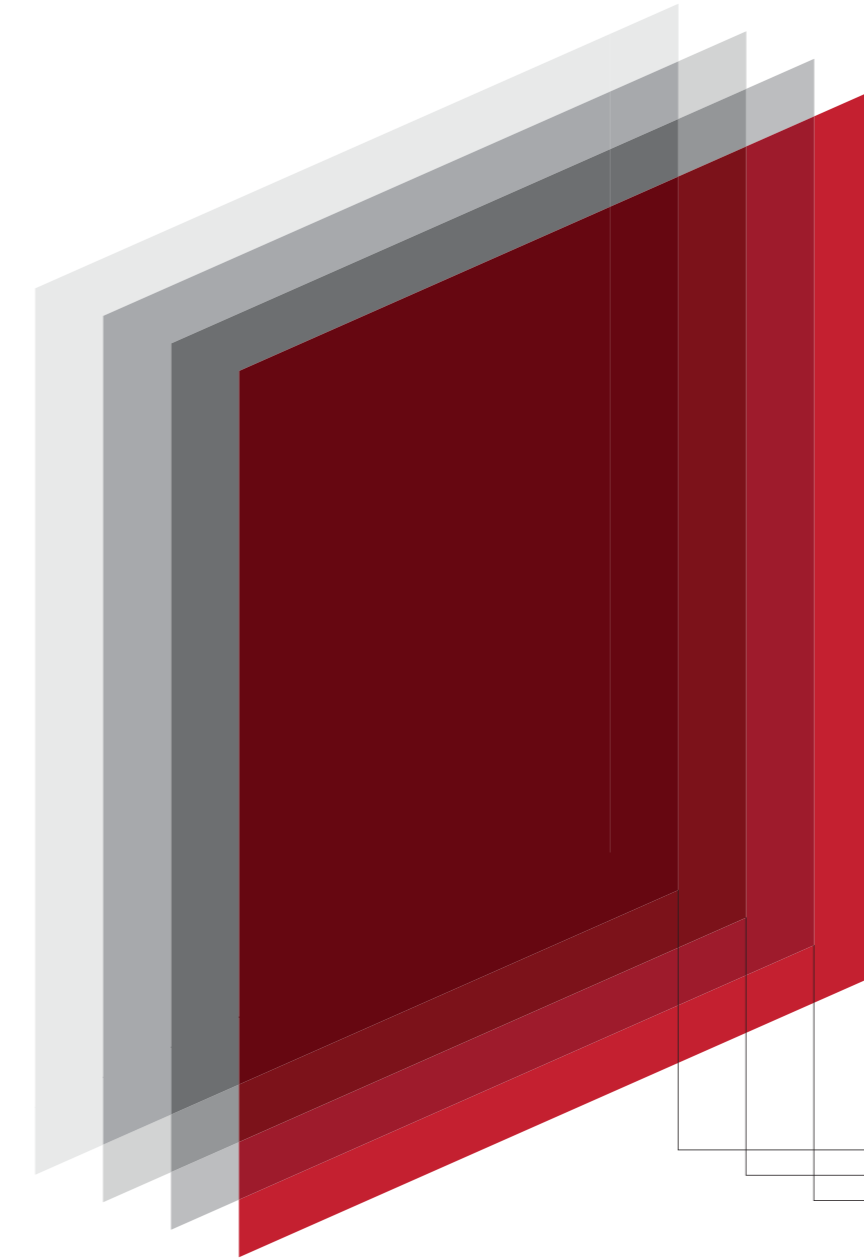
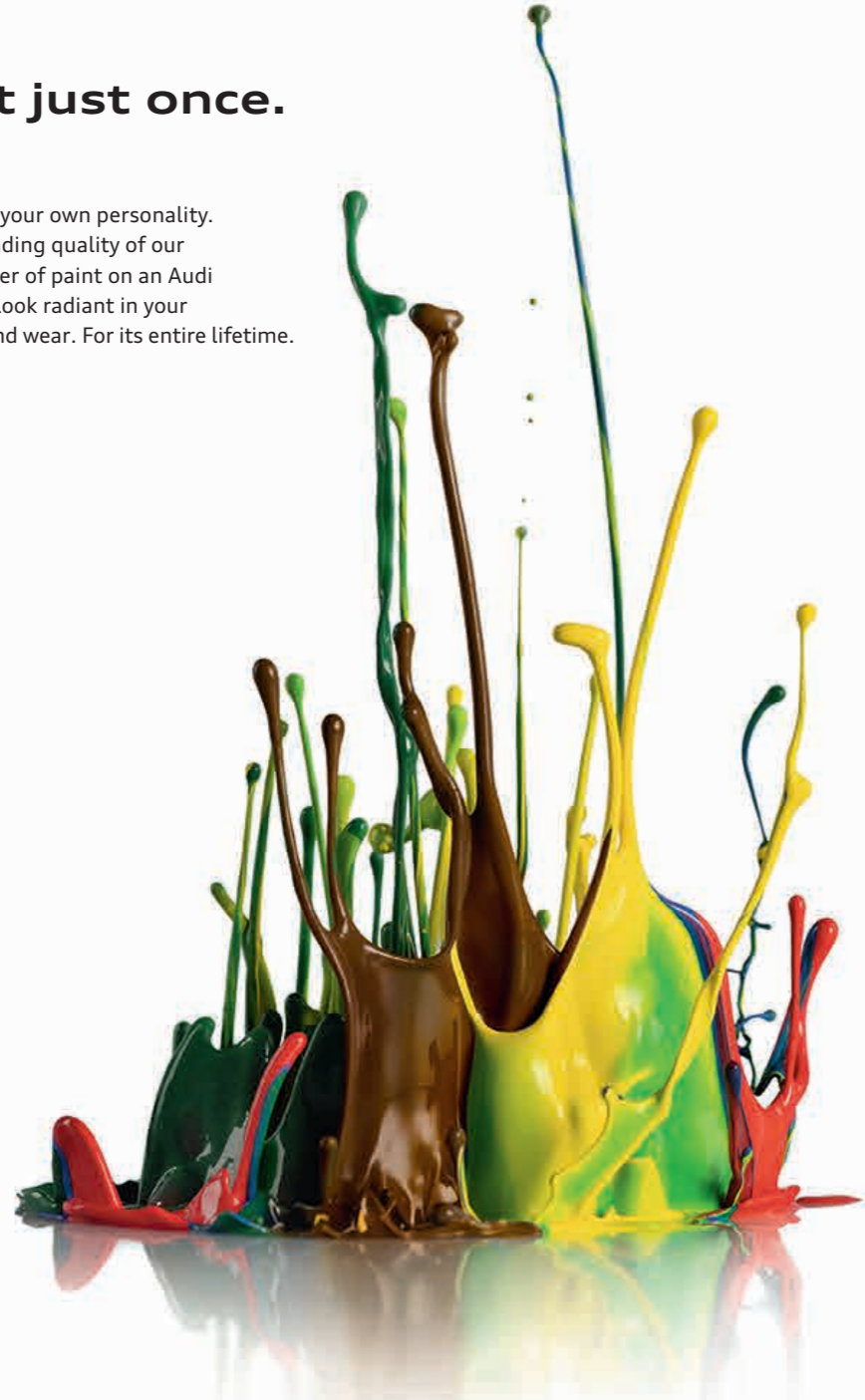

In our view, millimetre precision is simply not enough to ensure you will still be able to enjoy your favourite colour for your Audi even after driving many thousands of kilometres. That is why we deliver precision on the micrometre scale, and why it takes top priority even for the primer coat. The first layer protects the body from rust and other symptoms of old age. The filler layer compensates for even the tiniest of irregularities and has an elastic effect, stopping the paint flaking off, if for example, gravel is thrown up. The third layer is the visible colour. Then comes a fourth layer of clear varnish, which protects the paint finish from UV rays and gives it a sheen and depth of colour that will ideally last for a long time – until you decide on a new favourite colour.

Primer coat
Filler layer
Coloured paint
Clear varnish

| Solid paint finishes



Carrara white

| Metallic paint finishes



Floret silver, metallic



Orca black, metallic

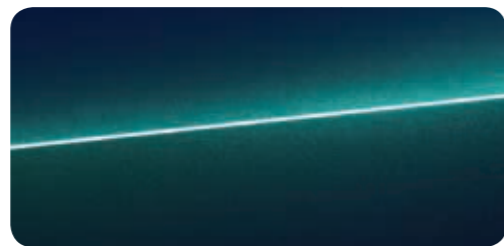

Galaxy blue, metallic

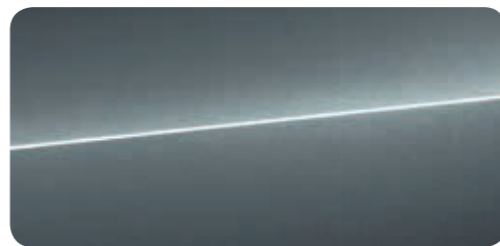

Samurai gray, metallic

Solid/metallic paint finishes

Front and rear bottom bumper section and sill trims and wheel arch trims grained in anthracite, door trim strips with quattro embossing and underbody protection, front and rear, in Barcelonetta silver





Quality given form. And a brilliant finish. Audi wheels.

To make sure you have peace of mind for every metre of your drive, Audi puts its wheels through an exacting series of specialised test procedures. Hardness tests, for example, aim for maximum stability, while a copper accelerated salt spray test – CASS for short – using acetic acid guarantees the greatest possible corrosion protection. Thanks to these and many other measures, we can ensure that every Audi wheel offers maximum quality – even after scores of kilometres. No matter which of the numerous designs you choose.

| Summer wheels



**Cast aluminium wheels
in 5-spoke star design***
size 8.5 J x 48.26cms with 255/55 R 19 tyres

Tyre pressure monitoring system

Sensors monitor the air pressure set in the tyres throughout the journey. Visual and acoustic warning if the pressure drops in one or more tyres; display in the driver information system and the MMI. Air pressures and temperatures of the individual tyres are displayed in the MMI system whilst driving.



Premium quality you can rely on.

You have a special place in your Audi. Exclusive comfort can be felt on the front and rear seats: thanks to high-quality materials and first-class workmanship. Whether you decide on standard seats with cloth or leather upholstery or sport seats or customised contour seats with stable lateral support for dynamic driving: you're sitting in the right place.



Standard seats, front

| Cricket leather

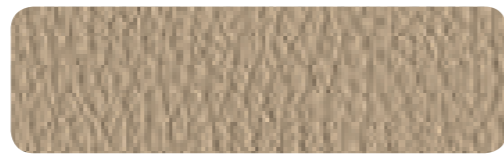

Cricket leather, pistachio beige



Cricket leather, black



| Cloth and leather upholstery and trim

Cricket leather upholstery and trim fully penetrated with dye, the leather provides outstanding surface protection thanks to the paint finish. The leather is extremely hard wearing and durable, tanned without the use of chromium and its grained surface gives an impression of high quality.

| Seating comfort

Front seats, electrically adjustable, including memory function for the driver seat with electric adjustment of seat height, fore/aft position, seat and backrest angle as well as electric 4-way lumbar support; 2 pre-sets for the electrically adjustable driver seat, the exterior mirrors and the electric steering wheel adjustment

Comfort centre armrest, front

with fold-open storage compartment, fore/aft position can be adjusted separately for driver and front passenger

Airbags

8 airbags including rear side airbags

| Seats in the rear



Centre armrest, rear

in the rear seat backrest, foldable, including 2 cup holders



Rear seat bench plus

seats of the 2nd row allow individual manual adjustment of fore/aft position at a ratio of 35:30:35 as well as the backrest angle. The 3 seats of the rear seat bench can be folded down 35:30:35 (level loading floor) The 2 outer seats include additional double-folding mechanism. Rear centre armrest with 2 cup holders; including ISOFIX child seat mounting and Top Tether for all 3 seats





A fine finishing touch.

Not just any wood is allowed to adorn the interior of your Audi. The fine veneers for the inlays are stripped from the trunks and so-called root burls. Normally, a set of veneers for one car comes from just one burl or trunk to minimise variation. The production process utilises both state-of-the-art machines and the oldest tool in the world – the human hand, with some parts being crafted and polished manually to give them a unique feel.

| Upper inlays



Brushed aluminium, sono

| Lower inlays

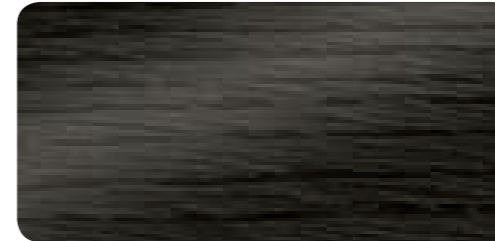

Walnut, terra brown

| **Headlights****Audi Matrix LED headlights***

the innovative technology combines a camera system with LED light sources and precision optics for highly adaptive light distribution. The system blanks out light that would otherwise shine directly on oncoming vehicles or vehicles in front but continues to fully illuminate all the other areas in between and alongside. The front lighting thus adapts dynamically, providing the driver with a much wider visual range. The conventional division between dipped and high beam is dispensed with. Familiar convenience functions such as the static turning light, all-weather light, junction light, motorway light and travel mode, which uses GPS data to switch between right-and left-hand drive modes are integrated into the LED technology. The LEDs of the Audi Matrix LED headlights also perform the dynamic cornering light functions. Using data from the navigation system for assistance, the cornering light function starts responding shortly before the steering wheel is turned. Distinctive features include the crisp lighting pattern of the LED daytime running lights. Including headlight cleaning system

LED headlights

allow precise, near-daylight illumination of the road; combining LED dipped beam, high beam, daytime running lights, motorway light, indicator and static turning light as well as all-weather light; including headlight cleaning system; motorway light that automatically increases headlight range from a speed of approximately 110km/h; all-weather light to reduce the risk of the driver being dazzled when visibility is poor; striking light pattern in day and night design configurations; low power consumption and long service life, including high-beam assist

LED rear lights with dynamic indicator

same functions as the LED rear lights, but additionally feature a dynamic and quickly recognisable lighting pattern for the indicators. The segments of the LED light band are illuminated in turn within milliseconds, creating a pulse of light that runs outwards in the direction in which the car is turning. In conjunction with LED headlights and Audi Matrix LED headlights

High-beam assist

improves the driver's visibility and ensures a more relaxed drive thanks to the extra comfort and convenience. Depending on the traffic situation, the high beam is automatically switched on or off. Working within system limits, automatically detects the headlights of oncoming traffic, the rear lights of other road users and light sources in built-up areas. In conjunction with the optional night vision assistant, the networked vehicle functions support the marking light for detected pedestrians for more safety when driving at night

Light/rain sensor

to control the automatic lights-on function and the automatic windscreen wiper function, including coming home/leaving home function: delayed switching-off/automatic switching-on of the main headlights, rear and number plate lights when parking/opening the vehicle

| **Interior lighting****Interior lighting in LED technology**

in the front and the rear and one for the optional 3rd row of seats, including capacitive reading lights in front, reflected lighting on centre console, vanity lights, front and rear footwell lighting, glove compartment light, front and rear entry lights, front and rear inside door handles, active door warning lights, luggage compartment lights to the right and left as well as courtesy lighting in the luggage compartment lid for easy loading and unloading

Lighting package

in addition to interior lighting: contour lighting for dashboard and front and rear door trim; lighting of front and rear door pockets with capacitive activation (contactless light control); front and rear ambient door lighting; courtesy lighting in door handles

Ambient lighting

In addition to lighting package:

- Ambient lighting for the centre console
- Contour lighting for the centre console illuminated
- Door sill trims, front/rear
- 3 predefined colour profiles; additional interactive, custom colour profile. The interactive colour profile is controlled via the Audi drive select modes. The colour adjustments are for the contour and ambient lighting features

| **Exterior design****Audi Singleframe**

radiator grille in dark grey, structured, matte; one-piece trim frame in aluminium around the radiator grille, with horizontal struts in aluminium; with Audi rings

Body

lightweight unitary body in multi-material design, front and rear areas feature defined crumple zones

Model name/logo

model/technology name on the luggage compartment lid, quattro logo in the radiator grille and the dashboard on the passenger side; on request also available without the model/technology name on the rear

Roof rails

for safe transportation of items; strong and aerodynamically shaped, in anodised aluminium

Exhaust tailpipes

dual-branch design, with rectangular trims

Gloss package

window slot trims in aluminium look, outer B and C-pillar trim in gloss black

| Steering wheels/controls



Leather steering wheel in 4-spoke design with multifunction plus and shift paddles with 14 multifunction keys for conveniently operating the available infotainment features, such as audio skip, activation of the voice control system, NAV or freely programmable buttons; adjustable in height and reach; with full-size airbag; includes selector lever knob in leather; colour coordinated with the selected dashboard top side

| Electric steering wheel adjustment

adjustable in height and reach, with automatic entry and exit function

| Selector lever knob in leather

colour coordinated with the selected vehicle interior colour and to match the dashboard top side

| Mirrors

Exterior mirrors with integrated LED indicator electrically adjustable, heated and folding, including automatic kerb-side function for the exterior mirror on the passenger side, convex, flat or aspherical mirror glass; body-coloured housing

also with:

| automatically dimming with memory function on both sides

the automatic kerb-side function tilts the exterior mirror on the passenger side downwards when reverse gear is selected, giving the driver a better view of the kerb

| Interior mirror, auto dimming

in same colour as headlining

| Roof system



| Panoramic glass sunroof

2 sections, electrical activation to raise and open the front glass section; tinted glass insert and an electrically operated sunblind as well as convenience closing/opening via vehicle key; ensures a comfortable interior that is flooded with light; improved interior climate by means of efficient ventilation

| Glazing

| Double sun visor

for driver and front passenger; simultaneous front and side protection possible; gap between visor and door pillar can be closed by means of pull-out extension

| Sunblind

manually operated for the rear window and the rear door windows

| Climate control



| 4-zone deluxe automatic air conditioning

in addition to deluxe automatic air conditioning: air-conditioning controls in front with large TFT display and capacitive toggle switches, additional air-conditioning controls with digital display for the climate control in the rear with separately adjustable temperature and blower settings and air distribution left and right (rear functions can also be set from the front air-conditioning controls), diffuse ventilation via air nozzle strip on the front-passenger side, air nozzle strip with chrome application on the centre fin, additional air vents in the B-pillars, automatic air recirculation mode using an air quality sensor, use of residual heat, separate regulation of footwell temperature in front, individually adjustable for driver and front passenger via MMI, personal settings can be stored

| Closing systems

| Luggage compartment lid, electrically opening and closing

opens via a button on the vehicle key or in the driver door or by means of the soft-touch button in the luggage compartment lid handle recess; closes via a button on the inside of the luggage compartment lid, the button in the driver door or the optional convenience key (long press). Including power-assisted closing and programmable luggage compartment lid opening angle

| Storage compartments

storage compartment in the front and rear door trims, e.g. for bottles up to 1 litre, storage nets on the reverse of the front seat backrests, storage compartment in the centre console; glove compartment on the front-passenger side, lockable, large volume, illuminated, with holder for writing utensils; 2 cup holders on the centre console and one 12V socket



| Rail system with load-securing kit

in the luggage compartment, with telescopic rod, attachment strap and variable lashing points for individual partitioning of the luggage compartment and for securing objects; including bag for storing small parts

| Electric luggage compartment cover

electrically opening and closing luggage compartment cover; for comfortable loading of the luggage compartment; can also be operated manually; including stainless steel loading sill cover

| Instrument clusters/display instruments



Driver information system with colour display displays a host of useful information on a high-resolution 17.78 cm colour display in the instrument cluster. Attention assist provides a warning via acoustic signal and visual warning if the system determines that the driver's attention is lapsing. An integrated efficiency program provides fuel consumption data overviews

Audi virtual cockpit*

innovative, fully digital 31.242 cm instrument cluster for the flexible display of information tailored to the drivers needs such as: vehicle speed/engine speed, map representation, radio/media information etc.; the Audi virtual cockpit is operated via the multifunction steering wheel. The VIEW button on the multifunction steering wheel allows you to change between 2 differently sized representations of the round instruments. The display with small instruments allows the onboard computer and MMI contents to be shown on a large clear area of the display. The configuration of onboard computer values in the rev. counter is possible. In conjunction with MMI navigation plus with MMI touch. Display of navigation map as 3D terrain model on a high-resolution 31.242 cm colour display; permanent display of navigation information near the speedometer when route guiding has been activated. The attention assist provides a warning in the Audi virtual cockpit and via acoustic signal if anything indicates that the driver is starting to become inattentive. The attention assist is active between 65 km/h and 200 km/h and can be deactivated

| Radio/Navigation systems

**MMI radio plus**

- Bluetooth interface
- with high-resolution, vertically extending 17.78 cm colour display and separate MMI control panel, including car menu
- 17.78 cm TFT instrument cluster in colour and driver information system
- offset MMI control panel
- CD player (MP3, WMA, ACC capable), 1 SDXC card reader, AUX-IN connection
- Audi music interface (2 USB interfaces, 1 with charge and data function, 1 with charge function)
- AM/FM phase diversity
- Voice control
- GALA (speed-sensitive volume adjustment)
- Audi sound system

**MMI navigation plus with MMI touch***

- Navigation system with high-resolution 21.082 cm colour display
- 3D map representation with display of lots of sightseeing information and city models
- MMI search: free text search with intelligent destination suggestions during entry
- Detailed route information: map preview, choice of alternative routes, POIs, lane recommendations, motorway exits, detailed junction maps, etc.
- MMI touch: touch-sensitive control panel for fast, intuitive operation, e.g. destination entry by means of handwriting recognition as well as free movement and zooming in the map
- Easy operation of the infotainment via natural language with address entered in a sentence
- Access to smartphone voice control
- Additional display of navigation map in 17.78 cm driver information system or in optional fully digital 31.242 cm Audi virtual cockpit
- MMI radio plus
- BOSE 3D sound system
- Flash memory for music (10 GB)
- DVD player (MP3, WMA, AAC and MPEG-4 capable) for music CDs and video DVDs
- 2 SDXC card readers, AUX-IN connection
- Audi music interface for connecting portable media players via the USB interface (2 USB interfaces, 1 with charge and data function, 1 with charge function) or Wi-Fi
- Bluetooth interface for hands-free use and audi streaming
- Display of emails and messages from mobile phone in selected languages including read-out function

*Optional

| Sound systems

**Bose 3D Sound System***

impressive sound reproduction with 19 loudspeakers including 3D Sound loudspeaker, centre speaker and subwoofer, 15-channel amplifier with a total output of 558 watts; spatial sound reproduction with the new sound feature 3D Sound for the front seats. This is created by means of additional loudspeakers in the A-pillar, the midrange speakers and Bose Advanced Staging Technology. The 3D sound can be created with all sources. This creates a uniquely authentic 3D surround experience in the vehicle, giving the impression of sitting in the first row of a concert hall. Lighting in the loudspeaker covers

The 3D Sound concept:

First a semantic analysis process is applied to separate the individual sound components within the audio signal into direct sound, early reflections and reverberation. Then the algorithm from the Fraunhofer technology Symphoria intelligently distributes the separated audio objects in the vehicle without adding artificially generated components to the music signal. This results in high-quality 3D surround sound

Audi sound system

impressive sound thanks to 6-channel amplifier with a total output of 180 watts and 10 loudspeakers including centre speaker and subwoofer

| Phone

**Audi smartphone interface**

The Audi smartphone interface connects your smartphone to your Audi. It takes the smartphone contents directly to the MMI display smoothly via USB. Navigation, telephone system, music and selected third-party apps can be conveniently controlled via the MMI controller as well as the voice control system.

Bluetooth interface

Allows hands-free calls to be made in the vehicle using the microphone and, depending on the mobile phone compatibility, Bluetooth audio streaming. Bluetooth-capable mobile phones can be connected to the vehicle via the interface

Audi phone box

allows phone calls with improved reception quality by placing mobile phone into the compartment in the front centre console; can be charged via USB connection hands-free facility and voice control (phone); low SAR radiation in the interior of the vehicle thanks to connection to vehicle aerial; operated via radio/navigation systems or the multifunction leather steering wheel

| mySmartphone

**Access to smartphone voice control**

MMI navigation plus (incl. voice control system), Bluetooth interface and multifunction steering wheel allow the use of the voice control of the mobile phone (e.g. Siri from Apple iPhone) connected via Bluetooth. The smartphone voice control is activated by pressing and holding the key for the voice control system on the multifunction steering wheel; uses the vehicle's microphone and loudspeaker for optimal voice recognition and sound whilst driving

*Optional

| Assistance systems

Hold assist*

stops the vehicle over an indefinite period of time in the uphill or downhill gradients usual in traffic. The system is activated by push-button and allows the driver to drive away smoothly

Cruise control

at speeds from about 30 to 250 km/h and above, the system keeps the set speed constant, provided that engine power and engine braking effect permit it; operated via separate steering column stalk, set speed displayed in driver information system. The LIM button can be used to switch between the cruise control and the programmable speed limiter. In speed limiter mode, driving proceeds with the accelerator as normal, but the driving speed is limited to the set speed. This speed limit can be temporarily deactivated/overridden by kickdown. The speed limit is operated and adjusted using the same functions as the cruise control and the adaptive cruise control. The programmable speed limiter can be adjusted between 30 and 250 km/h in single and 10 km/h steps

| Assistance systems – City

Audi pre sense basic

automatically initiates any required preventive measures for your protection and that of other passengers; these include: tensioning of the front seat belts to minimise occupants shifting forward or to the side, activation of the hazard warning lights and the closing operation for the panoramic glass sunroof (if ordered) and windows; categorises driving situations by linking different vehicle systems

| Parking systems



Park assist*

searches for suitable parking space along the road by means of ultrasonic sensors and provides support when parking and leaving by means of independent steering action. Calculates the right parking path for perpendicular parking spaces and the right parking and exiting paths for parallel parking spaces. The driver has to accelerate, apply the brakes and monitor the parking process. The display of the surroundings warns the driver of any obstacles at the side of the vehicle in accordance with the steering angle. Parking in several moves is supported. Optionally available in addition with reversing camera or 360 degree cameras; activated via a button on the centre console

Parking system plus

acoustic and visual front and rear parking system assists with parking and manoeuvring. Shown in the MMI display; measurement by ultrasonic sensors concealed in the bumpers; optionally available with additional reversing camera or 360 degree cameras. Activated by selecting reverse gear, via a button in the centre console and automatically as soon as the distance to a recognised object is less than approx. 90 cm

Reversing camera

image of area behind the vehicle shown on the MMI display, with dynamic display modes showing the path calculated based on steering angle; auxiliary lines and guidelines as well as indication of the point at which to apply opposite lock when parallel parking; reversing camera integrated discreetly in the handle strip of the luggage compartment lid; activated by selecting reverse gear or via a button on the centre console. Choice of 2 modes (perpendicular parking mode and, with factory-fitted trailer towing hitch, trailer mode)

| Driving dynamics/brakes



adaptive air suspension

automatically regulates the vehicle height and damping by means of the electronically controlled air suspension with infinitely variable adaptive damping system on all 4 wheels; including level control and rear lowering to facilitate loading; 5 different modes (auto, comfort, dynamic, allroad, lift/offroad) set via the MMI system; in conjunction with MMI navigation plus with MMI touch including tilt angle display



Audi drive select

allows vehicle characteristics to be set in the available modes auto, comfort, dynamic, efficiency, allroad, offroad or lift/offroad and also custom-set by adjusting the power steering assistance, engine characteristics, gear changing characteristics, adaptive air suspension (optional), with additional optional equipment that can also be adjusted. The efficiency mode shifts the engine, transmission, climate control and optional adaptive cruise control or cruise control to a more fuel-efficient basic setting

| Driving dynamics/brakes

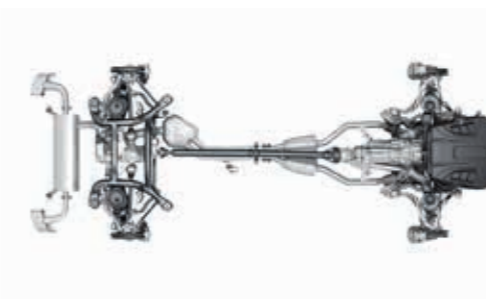

quattro

quattro permanent all-wheel drive with asymmetric/dynamic torque distribution through a self-locking centre differential and wheel-selective torque control. The system integrated in the Electronic Stabilisation Control (ESC) distributes the drive torque to all wheels depending on the driving situation by means of targeted braking actions. It actively countersteers in bends. The result is improved traction and dynamic performance when cornering and more precise and neutral handling (less understeer). Agility during steering is also improved

Electronic Stabilisation Control (ESC)

the brake control system's basic functions ABS, EBV, ESC, ASR and EDS provide high stability and increased traction by means of situation-dependent intervention in the engine management system and the vehicle braking system. The adaptive ABS uses offroad detection to optimise the braking performance depending on the driving surface. ESC offroad mode provides for increased traction and optimised stabilisation. The HDC supports the driver during critical downhill drives. The system automatically detects mounted roof racks and adjusts the ESC functions accordingly. All delay, stop and parking commands of the assistance systems are centrally coordinated and executed in the brake control system

tiptronic

8-speed automatic transmission with Dynamic Shift Program (DSP) and sport program; option of manual control via shift paddles on the multifunction leather steering wheel or by nudging the selector lever

| Technology/safety**Recuperation**

economises on fuel through brake energy recovery; kinetic energy is converted into usable electrical energy by increasing the generator voltage when the vehicle is coasting or braking and relieving the generator during subsequent acceleration

ISOFIX child seat mounting and Top Tether

standard bracket for the safe and practical fastening of ISOFIX child seats; includes additional attachment points on all rear seats and electric child-proof lock on the rear doors

You can obtain the recommended child seats from your Audi partner

ISOFIX child seat mounting for the front-passenger seat

with front-passenger airbag deactivation switch, includes separate electric child-proof lock for the rear doors

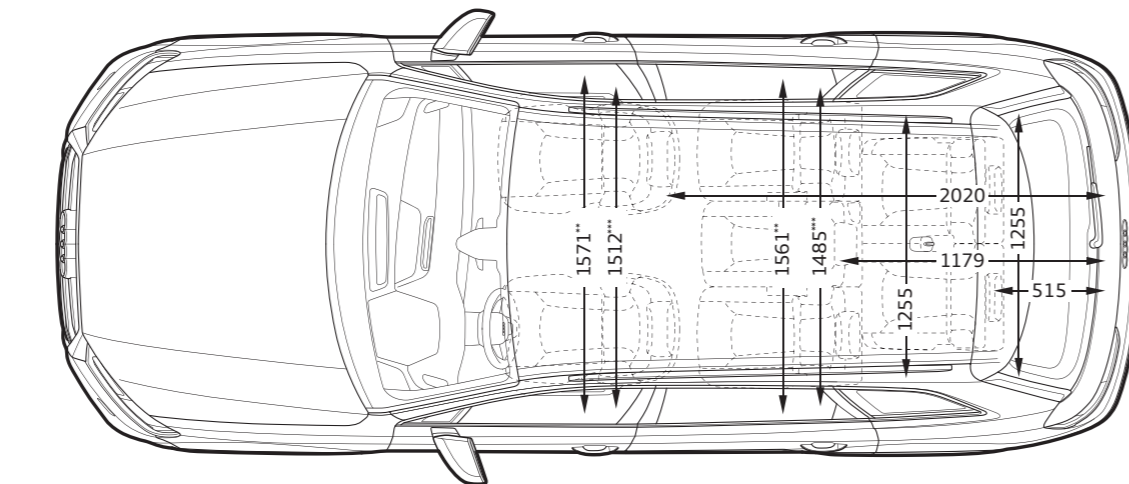
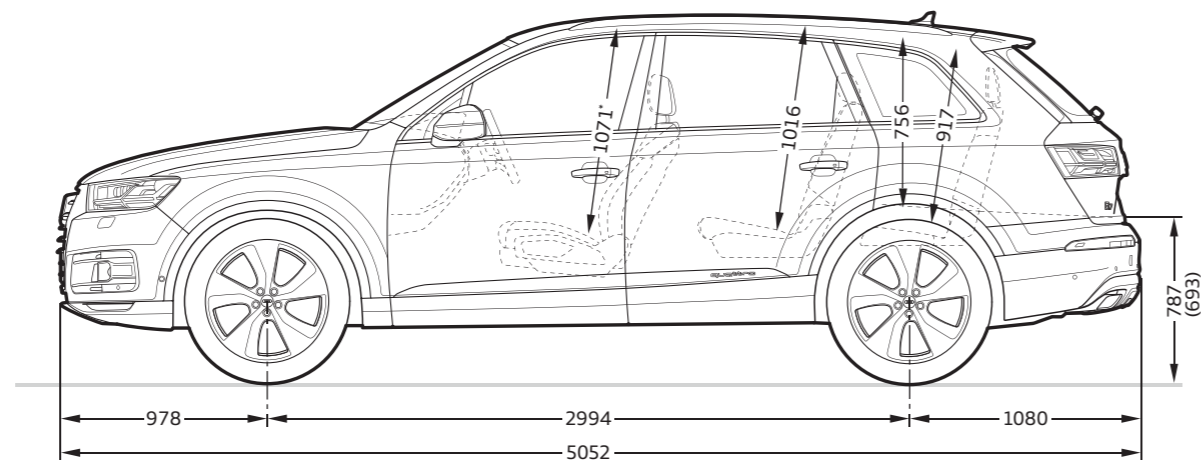
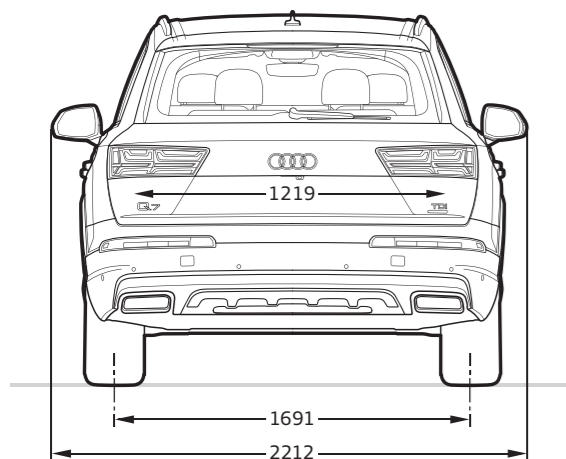
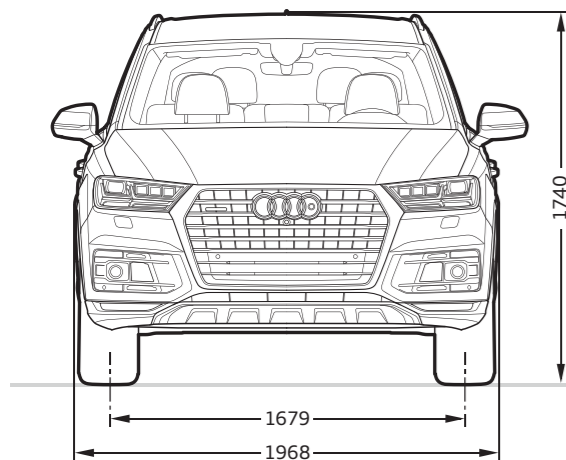

**Dimensions in millimetres.**

Dimensions were measured with vehicle at unladen weight.

Luggage capacity in l: 295/770/1,955 (second value: with 3rd row of seats folded down; third value: with the rear seat backrest folded down and vehicle loaded up to roof height).

Turning circle approx. 12.4 m.

*Maximum headroom.** Elbow room width.***Shoulder room width.

Model

Engine type

Displacement in cc (valves per cylinder)

Max. output¹ in kW at rpm

Max. torque in Nm at rpm

Power transmission

Drive type

Transmission type

Weights/capacities

Kerb weight² in kg

Gross vehicle weight in kg

Fuel tank capacity, approx. in l

Performance/consumption

Top speed in km/h

Acceleration 0-100 km/h in s

Fuel grade

Fuel consumption* in km/l

*ARAI Certified

**Audi Q7 45 TDI quattro
183 kW**

V6 diesel engine with common rail injection system and turbocharging

2,967 (4)

183/2910 - 4500

600/1,500-3,000

quattro permanent all-wheel drive

8-speed tiptronic

2,330

2,925

75

234

7.1

Sulphur-free diesel³

14.75

**Audi Q7 40 TFSI quattro
185 kW**

4-cylinder in-line petrol

1984 (4)

185/5000 - 6000

370/1600 - 4500

quattro permanent all-wheel drive

8-speed tiptronic

2,240

2,855

75

233

6.9

Petrol

11.68

Explanatory notes

- ¹ The figure given was calculated using the specified measuring procedure (current version of UN-R 85).
- ² Kerb vehicle weight includes driver (75 kg) and fuel tank 90% full, calculated in accordance with the current version of Reg. (EU) 1230/2012. Optional equipment may increase the car's unladen weight and drag coefficient, whereupon the possible payload limit and the top speed will be reduced accordingly.
- ³ We recommend using sulphur-free diesel complying with DIN EN 590. If this is not available, use diesel complying with DIN EN 590.

Important note

Special information about the wheels: Wheels with gloss turned finish as well as polished or partly polished aluminium wheels must not be used in wintry road conditions. For manufacturing reasons, the rim surface does not have sufficient corrosion protection for such use and can be damaged permanently by road salt or similar.



Audi Genuine Accessories. As individual as the life you lead.

Dynamic movement from A to B. And then, inspired, just keep driving. This is par for the course with your Audi Q7. Not least because it is prepared for a multitude of individual requirements from A to Z. Thanks to Audi Genuine Accessories. Products that will inspire you to new destinations again and again. And keep all our quality promises day in, day out. Benefit from customised solutions with convincing design and functionality. Because creativity in development and high production standards alongside numerous testing procedures are just as decisive for Audi Genuine Accessories as for the Audi vehicles themselves. Discover which tailor-made ideas Audi Genuine Accessories have ready for your lifestyle. A few highlights are illustrated here, but please contact your Audi partner for more information on the complete range.



The Audi Q7 sets benchmarks in many respects. Progressive design. Compelling performance. Innovative technology. Plus dynamics that delight, produced by powerful and efficient TFSI and TDI engines. Performance that reaches new levels, allowing you to get a head start on every journey.

But that is not enough. The extensive range of Audi Genuine Accessories provides you with the opportunity to adapt your Audi Q7 even more precisely to your individual needs. On the following pages, you will discover how you can lend a personal touch to your Audi Q7.



Sport and design

01 ▲



01 LED for entry area

For a bright entrance. Depending on the variant, either the quattro logo or the Audi rings are projected onto the ground by means of an LED light when the vehicle door is opened. Available in a two-part set for the driver and front-passenger side or for the rear vehicle doors.

02 quattro film set

The 'quattro' logo as a film set for the rear section of the vehicle on both sides. Available in either Brilliant Black or Ice Silver, metallic depending on the exterior vehicle colour.

02 ▲



03 Dark tinted tail light

Inside of light darkened, with transparent cover. Can be retrofitted to any halogen rear lights. Long service life and up to 50% lower energy consumption than halogen lights.

03 ▲





04 Wheel bags

Four-piece set with practical handles, enables easy and clean transportation and the storage of complete wheels. Made from tear-resistant plastic. Wheel bolts can be stored in the outside pockets.



04

Sport and design



05 Running boards

Stainless steel. Make it easier, for example, to stow items in the ski and luggage box on the roof. Rubber pads protect against the risk of slipping. Each running board has a load capacity of 200 kg.

06 Valve caps

The four metal valve caps with the embossed Audi logo provide better protection for the valve from dust, dirt and moisture. Available for rubber, metal and aluminium valves.

06



05

Greatness can be built upon.

In the Audi Q7, space has been re-envisioned. The luggage space is both generous and flexible – and can be expanded even further as required. Thanks to the transport solutions from Audi Genuine Accessories, you can significantly expand the vehicle's capacity in just a few simple steps. Be it additional luggage, skis, snowboards, kayaks or bicycles – use your own personal freedom to take whatever you need for enjoyment.



Transport

Luggage boxes

A new design from Audi featuring improved aerodynamics thanks to a flatter, sportier visual concept. Platinum Grey roof box with Brilliant Black side blades and chrome Audi rings for a high-quality, rivet-free look. The roof boxes are lockable and can be opened from both sides for comfortable loading and unloading. With internal handle for closing the box. Simple quick-action securing system including torque limitation. Positioned towards the front of the vehicle, making it easier to access the luggage compartment. Available in three sizes: 300 l (page 8), 360 l and 405 l. Can only be used in conjunction with the carrier unit. Further important information that will help you to choose the right roof box can be found on page 98.



Discover the special features of the shape and function of the new roof box. Simply scan the QR code using your smartphone or open the following link in your browser: www.audi.com/luggagebox. Connection costs depend on your mobile contract.

01 Luggage box

- a. 300 l
- b. 360 l
- c. 405 l

02 Bags for roof boxes

Robust yet flexible. These bags are equipped with a watertight floor featuring a watertight border extending 5 cm upwards. Ideal for making full use of the Audi roof boxes, as it is possible to use the individual bags in various combinations. Available in three sizes: S (43 l), M (76 l) and L (82 l).



▼ 01/02

03 Roof carrier bag (not pictured)

For storage or transport of carrier units and smaller roof rack modules. Made from durable material, with multiple loops and a side pocket for suitable tools or small parts.

04 Carrier unit for the roof rails

Carrier unit for various roof rack modules, such as the bicycle rack, kayak rack and ski and luggage box. The profile is made from anodised aluminium. The carrier unit is easy to install and is lockable. Maximum permissible overall weight for the carrier unit, roof rack modules and load: 100 kg.

► 04



Making pleasant journeys a reality.

Feel at home while on the road – with the communication solutions from Audi Genuine Accessories.

This range includes products such as Audi Entertainment mobile, which provides a fantastic cinema experience for passengers in the rear seats. With Audi wireless internet access, you can connect your mobile devices to the Internet conveniently, quickly and wirelessly. Regular navigation updates for the optional MMI are also available to prevent you from getting lost while surrounded by so much in the way of entertainment. You could hardly be any more relaxed when reaching your destination.

01 Audi Entertainment mobile*

The third-generation Audi Entertainment mobile promises premium entertainment with excellent image quality thanks to the 10-inch touchscreen – and all of this in the progressive Audi design. Offering an excellent stage for videos, photos, games and music, Audi Entertainment mobile includes software that is intuitive to use, numerous connection options (SD, USB 2.0, HDMI IN etc.) and a high level of functionality. By connecting to a Wi-Fi hotspot, users can access the internet. The device can be attached in the vehicle to the backrests of the front seats or used outside the vehicle. Requirement: preparation for Rear Seat Entertainment.



Communication

*Your Audi partner will be happy to provide you with more precise information regarding the launch date for this product.



Communication

02 Audi SD card (not pictured)

For storing your music: ultra-compact and universal SDHC memory card (16 GB), class 10. Comes with a protective case.

03 Audi USB memory key

The exclusive storage device that emulates the look of an authentic Audi vehicle key. The key has a memory capacity of 8 GB. The special 90° position for laptops makes the device particularly convenient to use. Suitable for all vehicles equipped with a USB connection or the Audi music interface. Can also be used as a USB stick outside the vehicle.



03 ▼



04 AUX cable

AUX cable for connecting a portable audio player (headphone output) to the AUX-IN socket in the vehicle. High flexibility thanks to different plug versions [housing shape, 1x angled (90 degrees), 1x straight outlet] for the two jack plugs. Compatible with many of the holders and bumpers on the market.



▶ 04



▶ 05

05 Wireless charging cover

Charges the iPhone 6/6s/7 via wireless charging according to the Qi-standard with 1A (5W). Cover to protect the iPhone. All elements (speaker, aux input, camera, push buttons) are exposable. Removable clip for alternatively synchronization/charging.

The smallest things often pose the greatest challenges.

The Audi Q7 is the Audi with the most space for children, with room for up to six child seats to fit comfortably. The family products from Audi Genuine Accessories ensure that comfort and safety are placed at the forefront for younger passengers as well as adults. For example, the Audi child seats are not just completely tailored to the vehicle – they also meet the highest standards in terms of their ergonomic properties. As a result, driving is just as fun no matter what seat you are in – and challenges are overcome effortlessly.

01 Audi child seat youngster plus

Offers excellent comfort thanks to intelligent belt guidance. The backrest is adjustable in height and width. Adjustments to set the seat size can be made with ease using a viewing panel. Suitable for children weighing between 15 and 36 kg (approx. 4 to 12 years of age).



Family



► 02

02 Child seat underlay

Tailored to the design of the child seats and the interior of the vehicle. Car seats are protected against dirt and potential imprints made by the child seats. Includes two practical storage pockets. Fully compatible with all Audi child seats, even where the ISOFIX base is used.

03 ISOFIX base for the Audi baby seat and Audi child seat (not pictured)

A more secure fit for the Audi baby seat and the Audi child seat. Can be installed and removed quickly. The adjustable support stand provides enhanced stability. Provides an optimum level of protection for the child. Note: The ISOFIX base is optional for the baby seat, but is mandatory for the child seat.



05 ▲



04 Child seat colour variants

All child seats are available in the colour combinations of Misano Red/Black and Titanium Grey/Black. The fabrics used are kind to the skin, breathable, non-fading, removable and washable, and are certified in accordance with the Oeko-Tex® Standard 100. Spare covers are available from your Audi partner.

05 Audi child seat

Can be used in the forward or rear-facing position. With adjustable seat shell, integrated seat belt and adjustable head rest. Can only be used in conjunction with the ISOFIX base. Suitable for children weighing between 9 and 18 kg (approx. 1 to 4 years of age).



Learn more about installing child seats. Simply scan the QR code using your smartphone or open the following link in your browser: www.audi.com/childseatinstallation. Connection costs depend on your mobile contract.

06 Audi baby seat

Easy to fit using the ISOFIX base (recommended). Can also be secured using the three-point belt. The integral full-belt safety harness provides improved restraint, while the attached cover offers protection from sunlight. With adjustable head rest. Suitable for small children weighing up to 13 kg (approx. 12 months).



► 06

Family

► 04





07 ▼

07 Backrest protector

A practical solution to prevent the backrest of your vehicle seat from getting dirty. Easy to wash. Also prevents children damaging the seat if they kick it while travelling in the back, and offers additional storage space in the form of four small pockets. Tailored to match the design of the child seats, the child seat underlay and the interior of the vehicle. Not suitable for integrated head rests.

08 Audi baby mirror

Easy to secure to the head rest of the rear seat thanks to the Velcro fastener, keeping the baby in the rear-facing baby seat in view. Viewing angle can be adjusted as required. Not suitable for integrated head rests.

09 Rubbish bin

A practical product for disposing of rubbish accumulated when travelling, with a waterproof interior compartment and a capacity of approx. 5 litres. Can be fitted to the backrests of the front seats. Easy to clean. Standard refuse bags can also be used and secured easily inside the rubbish bin.



08 ▼



▲ 09





The best means of protection is to think ahead.

Barely any other car offers you as much flexibility and freedom for your activities as the Audi Q7. Whether you are travelling for business or pleasure, with family, friends or your four-legged companion – nothing is left to chance. The comfort and protection equipment from Audi Genuine Accessories offers numerous storage options and also protects your Audi Q7 from many signs of day-to-day wear.

01 Business bag

More space for your business tools. The high-quality business bag offers you a storage volume of approx. 14 litres – enough space for a laptop of up to 15 inches as well as the various other things you need for the office. Can be securely fastened to the rear seat bench or the front passenger seat using the three-point seat belt. Can also be used outside the vehicle as an attractive briefcase.



01

02 Rear seat bag (not pictured)

An organised storage space for the rear seat bench. With its various interior mesh pockets, additional storage compartment and total volume of approx. 27 litres, the rear seat bag in high-quality Audi design provides plenty of space for the various items required on a long journey. Easily secured using the three-point belt. Includes a non-slip surface on the underside of the bag.

03

**03 Coat hanger**

For jackets, coats and other items of clothing. The coat hanger is fastened to the front head rests.

04 Seat back pocket

Additional storage capacity in a high-quality Audi design with various practical sections – for an even tidier interior. The pocket has a volume of approx. 11 litres and can be secured to the backrests of the front seats. The handles also enable it to be used outside the vehicle.



Comfort and protection

04

**05 Rear seat box**

A sturdy storage solution for various small items. The high-quality rear seat box with a volume of approx. 12 litres makes journeys even more comfortable. It can be secured to the rear seat bench in just a few steps using the standard three-point belt. Includes a mesh pocket with internal drawstrings to secure the contents.

06 Espresso mobile

With a pressure of 16 bar, the espresso mobile delivers true espresso enjoyment, complete with authentic crema. The set includes 18 illy ESE pods, two break-proof espresso cups, a microfibre cloth and an elegant case. Connection via the cigarette lighter in the vehicle interior.

05



06





07 Luggage compartment shell

Tailor-made luggage compartment protection – washable and robust. All-round edging prevents liquids from leaking onto the luggage compartment floor. Available for the 5-seater model variant.

08 Luggage compartment tray

For all those items of luggage that often leave marks when they are transported. The inlay is made from plastic and features high edges and a robust design; it is also easy to clean. Wide grooves reduce load slippage. Available for the 5-seater model variant.

09 Luggage net

Protects luggage against slipping. For fixing luggage into position via the lashing points in the luggage compartment.

10 Protective film for paintwork (not pictured)

Transparent and reduces the effects of stone chipping and other damage. Applied to the front of the vehicle.



08 ▼

09 ▼

Comfort and protection



11/12 ▲



11 Rubber floor mats

Made-to-measure. Offer improved protection against heavy soiling. Connected to the vehicle by means of the fastening points on the vehicle floor. With 'Q7' logo.

12 Premium textile floor mats

Tailored to the dimensions of the Audi Q7's floor. Made from hard-wearing, densely woven velour. With a special coating on the underside. The floor mats are always secured at the front of the vehicle using the points provided for this purpose on the floor. With 'Q7' logo.

13 Loading sill protective sheet (not pictured)

Perfect fit. Made from transparent sheeting. Provides the bumper with better protection against damage when loading or unloading the luggage compartment.

14 Mud flaps (not pictured)

Made from high-quality plastic. Reduce paint damage and dirt around the sill and rear apron panel. Available in sets of two for the front and/or rear.



15

15 Sun protection system

Almost complete protection from the sun. Made-to-measure two or three-part set for the side and rear windows. Easy to install and store.

16 Care products

Tailored to the high-quality materials used to construct your Audi. Suitable for numerous applications, either in the vehicle interior or for outer care, depending on the product.

17 Vehicle cover (for indoor use)

Ideal fit, in Anthracite, bearing the Audi logo. Made from a breathable and antistatic material. Piping accentuates the shape of the vehicle. Optimum protection from dust and dirt.



17



16



18 Rear protective cover

Protects large surfaces against dirt at the rear. The versatile zip-fastening system allows a dog to enter and exit the vehicle via the rear doors. Simple and fast to attach. Durable surfaces, water-tight and washable.

19 Safety harness for dogs

Safety harness for dogs that meets statutory regulations. Made from highly resistant materials including tear-resistant nylon and stainless-steel parts. Special padding helps to avoid pressure marks. With reflective strips in the chest area. Can also be used as a harness for use outside the vehicle.

20 LED gooseneck reading lamp

An extremely bright light exactly where you need it, thanks to the flexible silicone rubber neck. High level of stability in any position. Connection via the cigarette lighter.



20

18



19



Comfort and protection

Want to know more about the Q7? With pleasure.

Experience the world of the Audi Q7 at www.audi.com. Enjoy your journey of discovery.



Technical information

Luggage boxes

Volumes	300 l	360 l	405 l
External dimensions (L x W x H)	1,902 x 630 x 376 mm	1,756 x 826 x 376 mm	2,050 x 800 x 380 mm
Max. permissible load	60 kg	75 kg	75 kg

Wheel information

Please note the following information relating to wheels: Aluminium wheels with a high-gloss turned finish, or polished or partly polished aluminium wheels must not be used in the event of wintry road conditions. Due to the manufacturing process, the rim surfaces do not possess sufficient anti-corrosion protection and are at risk of long-term damage due to road salt or similar materials.

Information about fuel consumption, CO₂ emissions and efficiency classes for the ranges depends on the set of tyres/wheels used. The right to introduce modifications is reserved. Not to be reproduced, including in part, without the written approval of AUDI AG.

Audi India
Division of Volkswagen
Group Sales India Private Limited
Mumbai - India
www.audi.in
Valid from October, 2018

Printed in India
Q7 DJ 2

The models and equipment versions illustrated and described in this brochure and some of the services listed are not available in all countries. Some of the cars illustrated are equipped with optional features for which an extra charge is made. Details concerning the delivery specifications, appearance, performance, dimensions and weights, fuel consumption and running costs of the vehicle were correct to the best of our knowledge at the time of going to press. Deviations from the colours and shapes shown in the illustrations may occur. No liability is accepted for errors and printing errors. The right to introduce modifications is reserved. Not to be reproduced, including in part, without the written approval of AUDI AG.